

This drawing and the information contained herein is CONFIDENTIAL and PROPRIETARY to Friction Coating Corporation, is received in CONFIDENCE and shall not be used, copied, or disclosed to others without the written permission of Friction Coating Corporation. Doing so will result in legal action.

TUO Shoulder Grind Wheel ~ Angle

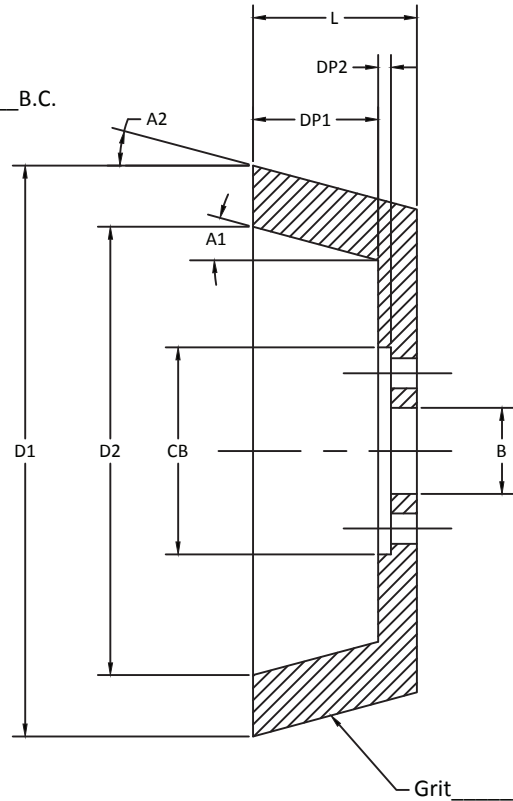
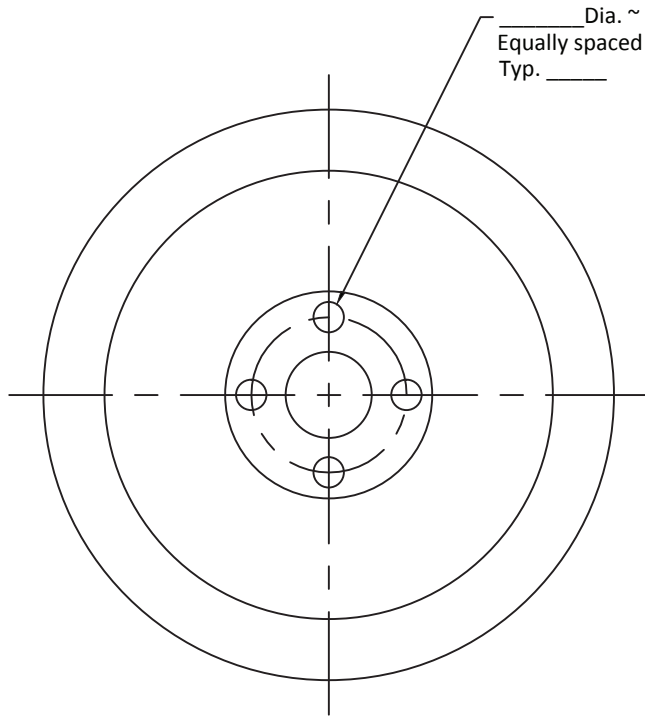

Shoulder Grind Wheel Information

D1. Diameter: _____

A1. Angle: _____

A2. Angle: _____

D2. Diameter: _____

B. Bore (Finish grind size): _____

CB. Counterbore: _____

L. Length: _____

DP1. Depth: _____

DP2. Depth: _____

Special Instructions:

Company: _____

Address: _____

City, State, Zip: _____

Country: _____

Contact: _____

Phone: _____

Fax: _____

E-mail: _____

Quantity: _____

P.O.#: _____



44833 Centre Court
 Clinton Township, MI 48038 • USA
 P 586.731.0990 • F 586.731.0991

Order Form

| | |
|--|--------|
| STANDARD TOLERANCES UNLESS OTHERWISE NOTED: | |
| 0.0000 | ±0.001 |
| 0.000 | ±0.005 |
| 0.00 | ±0.010 |
| MATERIAL | 1018 |

| | | |
|----------|-------------|-------|
| DATE | DRAWING NO. | |
| REVISION | DRAWN BY | SHEET |

| | | |
|------|-----------------|------|
| A | INITIAL RELEASE | |
| SYM. | REVISION RECORD | DATE |

* Grit selection: Use our "Grit Chart" located on the grinding wheel page.